

Installation Instruction Sheet

Linear Recessed Fixtures

INSTALLATION INSTRUCTIONS FOR MOUNTING RECESSED LINEAR FIXTURES

WARNING

To reduce the risk of death, injury or property damage from fire, electric shock, cuts, abrasions, falling parts and other hazards:

- Service of the equipment must be performed by qualified service personnel.
- Installation and maintenance must be performed by a person familiar with the construction and operation of this product and any hazards involved. All applicable codes and ordinances must be followed.
- Read this document before installing, servicing or maintaining this equipment. These instructions do not cover all installation, service and maintenance situations. If your situation is not covered, or, if you do not understand these instructions or additional information is required, contact Lux Illuminaire or your local agent.
- Read and follow all warnings and instructions provided by the LED manufacturer.

WARNING

- Before installing, servicing or maintaining this equipment, follow these general precautions. To reduce the risk of electrocution:
- Make sure the equipment is properly grounded.
- Always de-energize the circuit and/or equipment before connecting to, disconnecting from or servicing the equipment.

To prevent luminaire row from over-current:

- By adding the input current of each luminaire section marked on the luminaire, the total current per power feed must not exceed the maximum line wire amperage marked on the luminaire and the power feed cord/wire amperage rating whichever is the least.

To reduce the risk of fire:

- Keep material away that can burn from hot surfaces.
- Make sure LED boards are correctly installed.
- Use supply conductors with a minimum installation temperature rating as specified on equipment.

To reduce the risk of personal injury from cuts, abrasions or falling parts:

- Wear gloves to prevent cuts or abrasions from sharp edges when removing from carton, handling and maintaining this equipment.
- Do not use abrasive materials, glass cleaners or other solvents on reflector or lens. These substances may damage equipment and cause parts to eventually break and fall.
- Do not install a damaged fixture.

Installation Instruction Sheet

Linear Fixtures

MOUNTING TYPES & DIMENSION

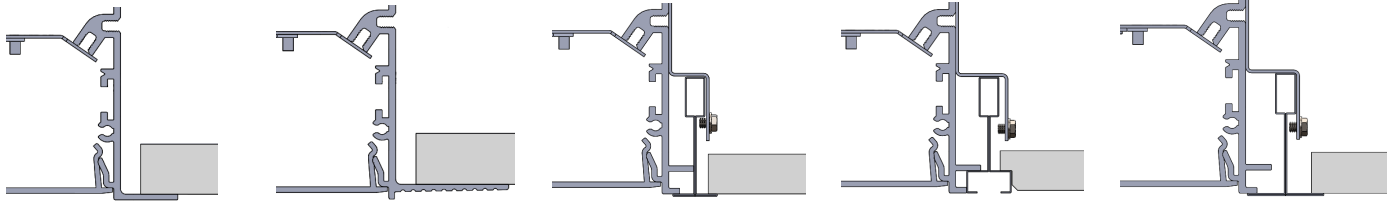

Flange

Flangeless/
Trimless

9/16" Grid
Tegular/Lay-In

9/16" Grid
Slot

15/16" Grid
Tegular/Lay-In

"Rough In" Width		
Mounting Type	3"	4"
Flange	3-5/8"	4-5/8"
Flangeless/Trimless	3-5/8"	4-5/8"

Grid Mounting Center Widths		
Ceiling Type	3"	4"
9/16" Slot	4"	5"
"9/16" Tegular/Lay-in	3-13/16"	4-13/16"
15/16" Tegular/Lay-in	4-1/8"	5-1/8"

Fixture Length	2FT	3FT	4FT	5FT	6FT	7FT	8FT
"Rough IN" Length For Flange & Trimless Only	24-7/16"	36-7/16"	48-7/16"	60-7/16"	72-7/16"	84-7/16"	96-7/16"

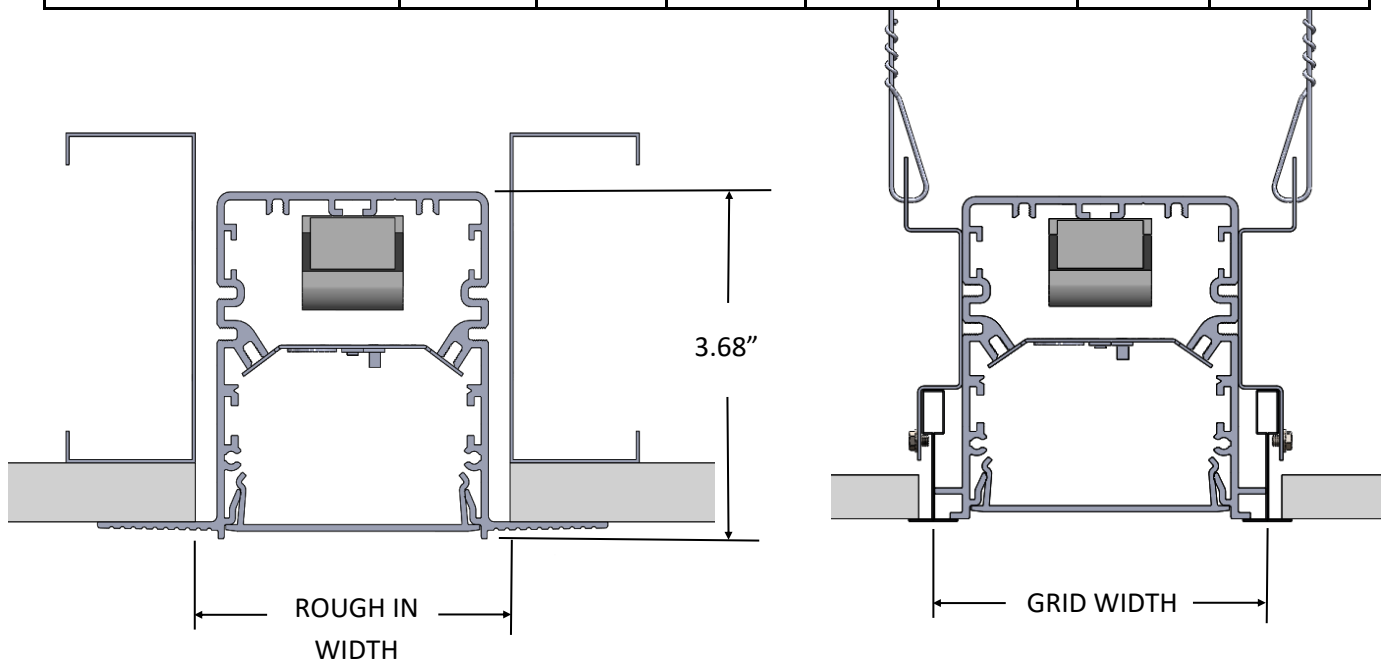

EOS Linear LED Recessed Luminaires

INSTALLATION INSTRUCTIONS FOR MOUNTING IN TEE GRID AND JOINING FIXTURES

Linear Fixtures

Remove lens.

Install hanger brackets on each side of fixture approximately 4" inches in from the ends. For 9/16" lay-in grid place smaller gap side of bracket towards lens. For other grids place wider gap side towards lens.

Set fixture into opening between Tee Grid. After the fixture is set, screw in #8 self threading screws in hanger bracket and attach support wiring to the building and fixtures.

Bring conduit and conduit fitting (supplied by others) to the power feed hole location at the end of the housing or in end cap. Make the electrical connections to the building power using the starter harness and plug into the fixture thru harness. Use the wiring diagram included to identify wiring.

For row mounting fixtures attach male end of harness to female end of harness.

Small lens sections are centered between fixtures to avoid leak at lens ends.

Slide fixture together using sliders that extend from fixtures to insure proper alignment.

Screw internal reflectors down to joining fixture.

Tuck harness at end of rows and attach end caps using supplied screws.

Grid end caps can be adjusted for lay in or Slot T configurations (use extra holes to adjust)

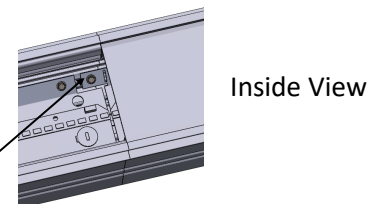
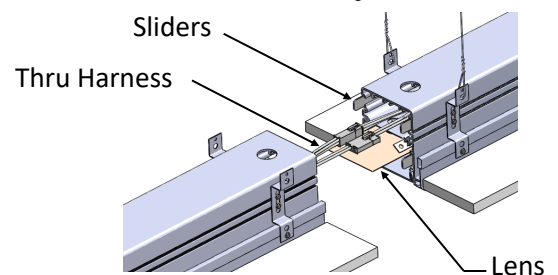
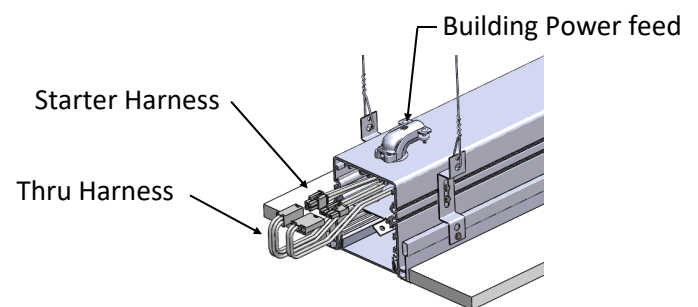
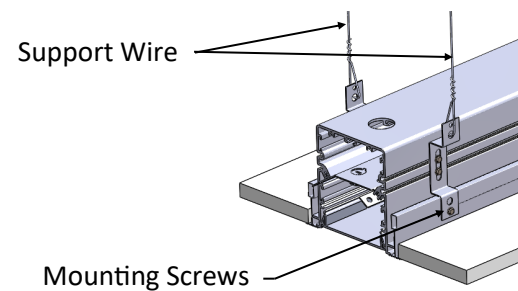
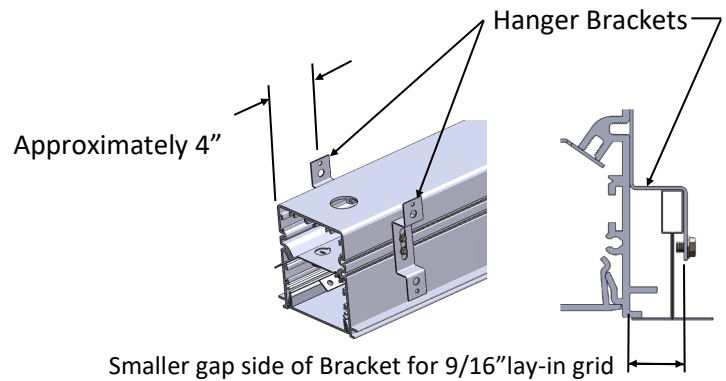

Fasten extended reflector tabs to joining fixture.
Break tab at end of run.

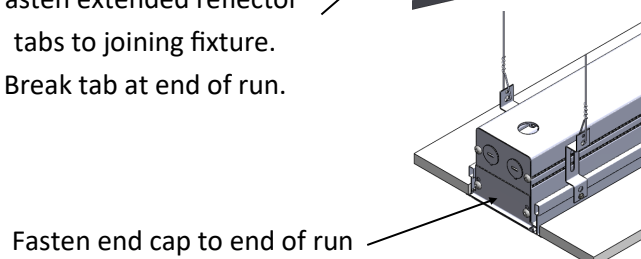

EOS Linear LED Recessed Luminaires

INSTALLATION INSTRUCTIONS FOR MOUNTING IN HARD CEILING AND JOINING FIXTURES

Linear Fixtures

Prepare wall/ceiling with proper rough-in width openings (see chart).

For post sheetrock applications use 5/8" holes on back of fixture. Tie into the building with 1/4" all thread rod (supplied by others).

Install building power feed conduit and fitting (supplied by others) thru top side of housing or thru end cap of 1st fixture in the continuous run. Make the electrical connections to the building power using the starter harness and plug into the fixture thru harness. Use the wiring diagram included to identify wiring.

Insert fixture thru rough-in opening and fasten fixture (hardware supplied by others) to building studs.

- Center fixture in opening
- **Pre-drill holes for screws and countersink 3/16" for Trimless fixture (if needed)**

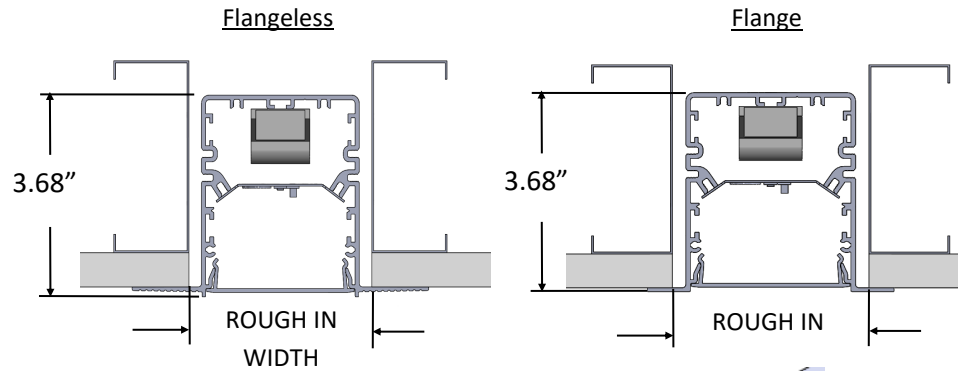

Building Power feed

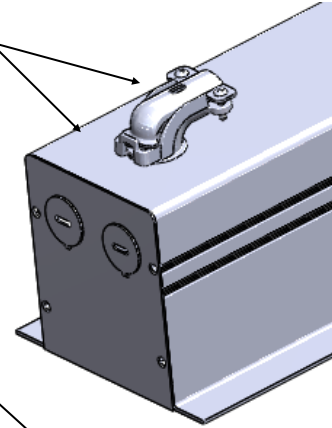

All thread
(supplied by others)

Post sheetrock applications

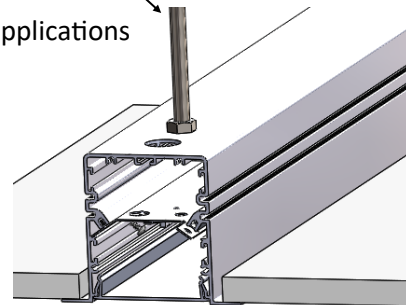

Flange

Trimless/Flangeless

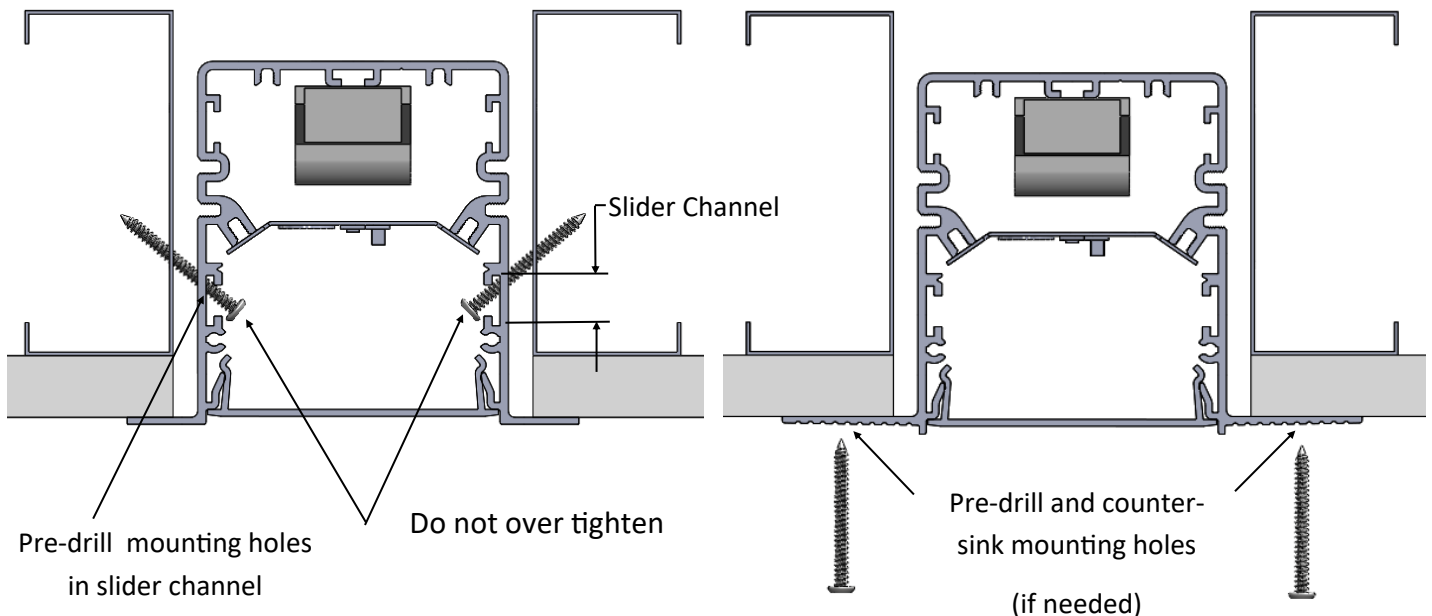

EOS Linear LED Recessed Luminaires

INSTALLATION INSTRUCTIONS FOR MOUNTING IN HARD CEILING AND JOINING FIXTURES (Continued)

Linear Fixtures

For row mounting fixtures attach male end of harness to female end of harness.

Small lens sections are centered between fixtures to avoid leak at lens ends.

Slide fixture together using sliders that extend from fixtures to insure proper alignment.

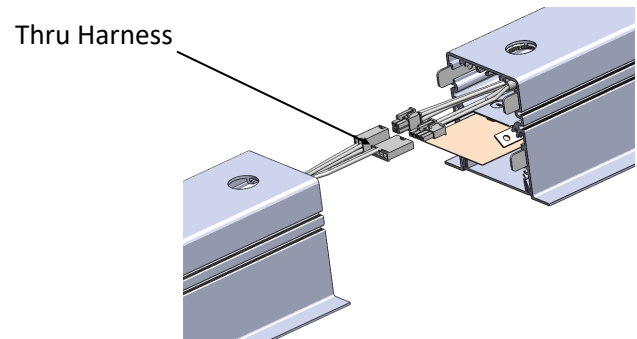
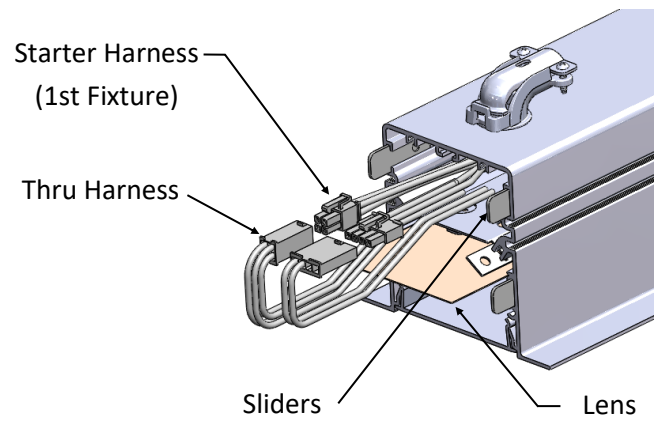

Screw internal reflectors down to joining fixture.

Fasten extended reflector tabs to joining fixture. Break tab at end of run.

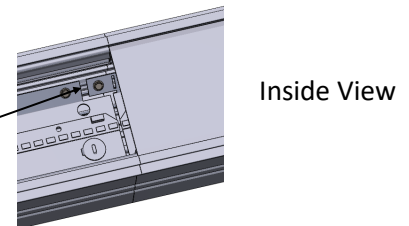

Tuck harness at end of rows and attach end caps using supplied screws.

Fasten end cap to end of run

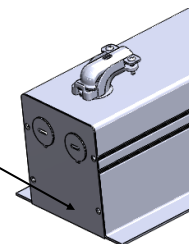

Replace Lens

Finish mud over flangeless trim making sure no screw heads are exposed.

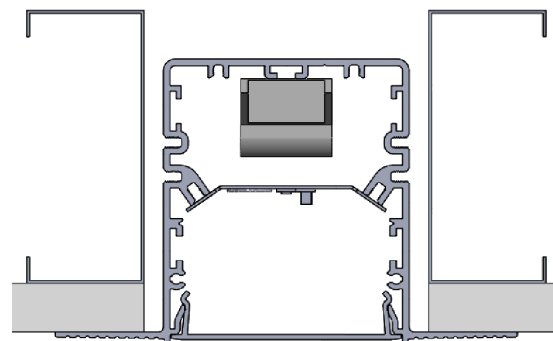

Clean around exposed area

Mud and sand over Trimless trim before painting

Corner Fixtures

Horizontal Drywall Corners

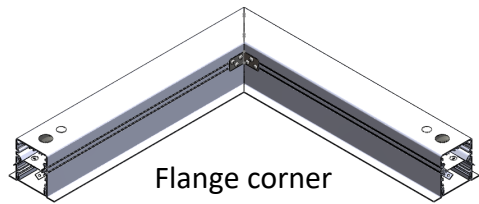
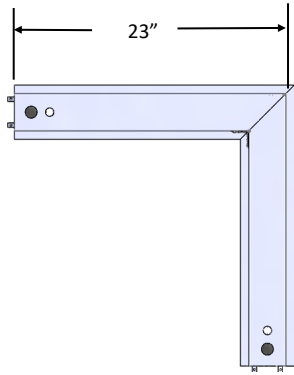

Flange corner

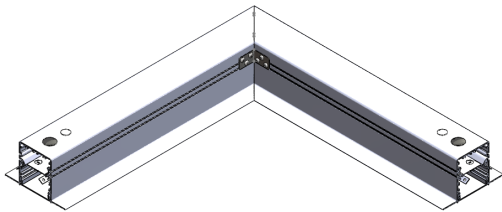

Trimless/Flangeless corner

Horizontal Grid Corner

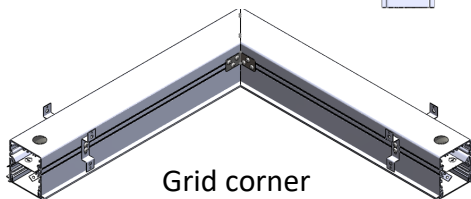
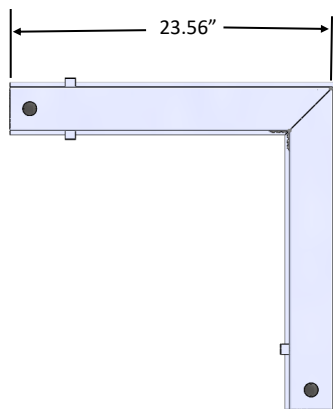

Grid corner

Vertical IN corner

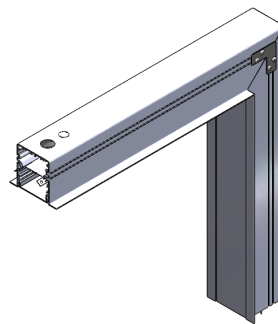
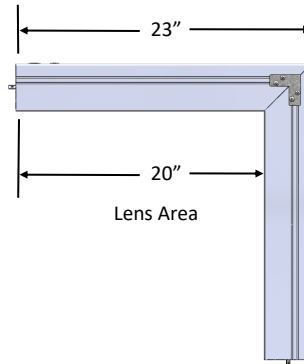

Flange corner

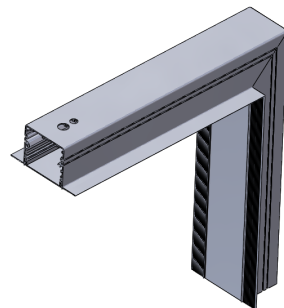

Trimless/Flangeless Corner

Vertical OUT corner

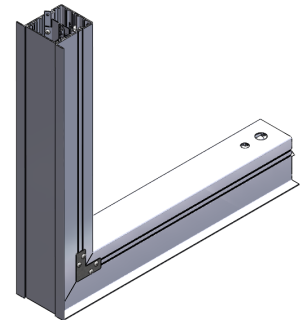
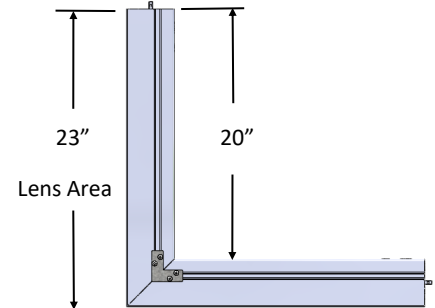

Flange corner

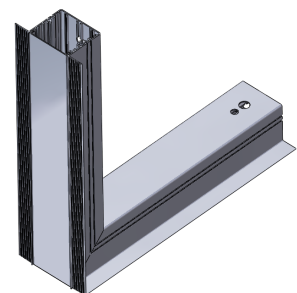

Trimless/Flangeless Corner

EOS Linear LED Recessed Luminaires

CORNER INSTALLATION INSTRUCTIONS FOR MOUNTING IN TEE GRID AND JOINING FIXTURES

Linear Fixtures

Use Chart on Page 2 to determine Grid mounting widths.

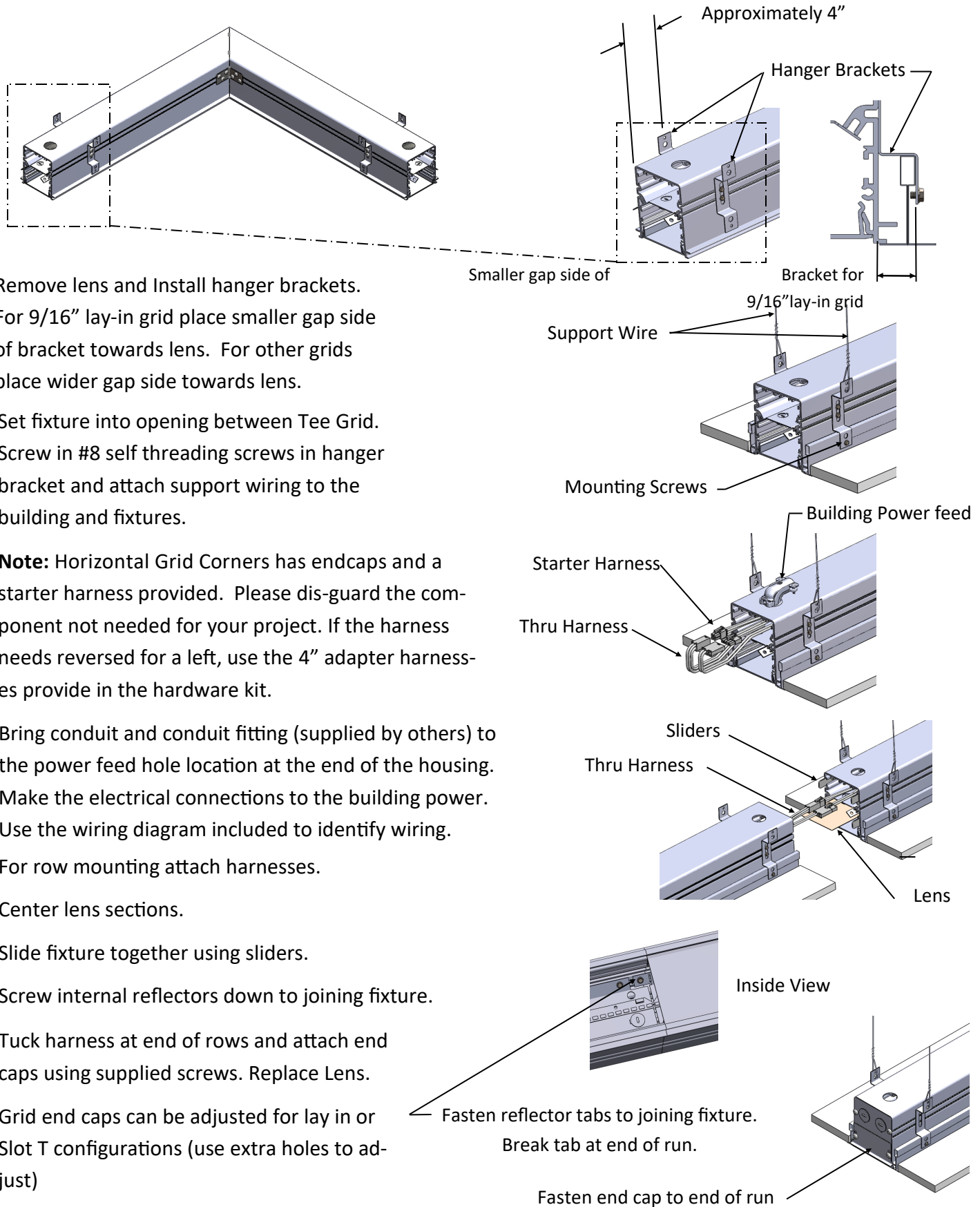

Remove lens and install hanger brackets. For 9/16" lay-in grid place smaller gap side of bracket towards lens. For other grids place wider gap side towards lens.

Set fixture into opening between Tee Grid. Screw in #8 self-threading screws in hanger bracket and attach support wiring to the building and fixtures.

Note: Horizontal Grid Corners has endcaps and a starter harness provided. Please dis-guard the component not needed for your project. If the harness needs reversed for a left, use the 4" adapter harnesses provided in the hardware kit.

Bring conduit and conduit fitting (supplied by others) to the power feed hole location at the end of the housing. Make the electrical connections to the building power. Use the wiring diagram included to identify wiring.

For row mounting attach harnesses.

Center lens sections.

Slide fixture together using sliders.

Screw internal reflectors down to joining fixture.

Tuck harness at end of rows and attach end caps using supplied screws. Replace Lens.

Grid end caps can be adjusted for lay in or Slot T configurations (use extra holes to adjust)

EOS Linear LED Recessed Luminaires

CORNER INSTALLATION INSTRUCTIONS FOR MOUNTING IN HARD CEILING AND JOINING FIXTURES

Linear Fixtures

Vertical IN corner

Vertical OUT corner

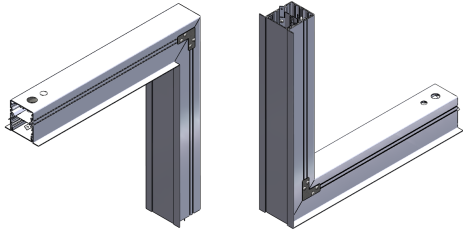

Trimless

Flange

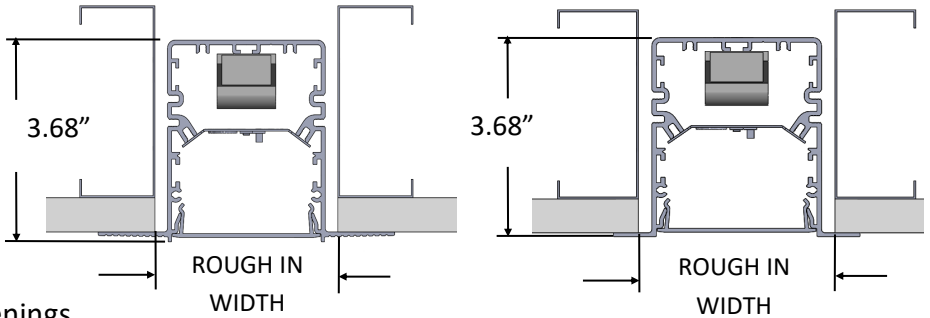

Prepare wall/ceiling with rough-in openings (see chart on page 2).

For post sheetrock applications use holes on back of fixture to tie into the building (supplied by others). Remove lens.

Install building power feed (supplied by others) thru top side of housing or thru end cap. Attach power to harness using the starter harness and plug into the fixture thru harness. Use the wiring diagram included to identify wiring.

Insert fixture thru rough-in opening and fasten fixture (hardware supplied by others) to building studs.

- Center fixture in opening
- **Pre-drill holes for screws and countersink 3/16" for Trimless/Flangeless fixture**

Building Power feed

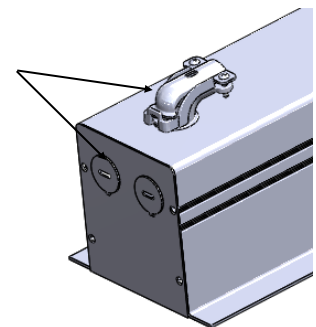

All thread

(supplied by others)

Post sheetrock applications

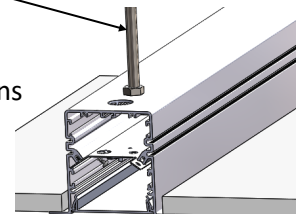

Flange

Trimless/Flangeless

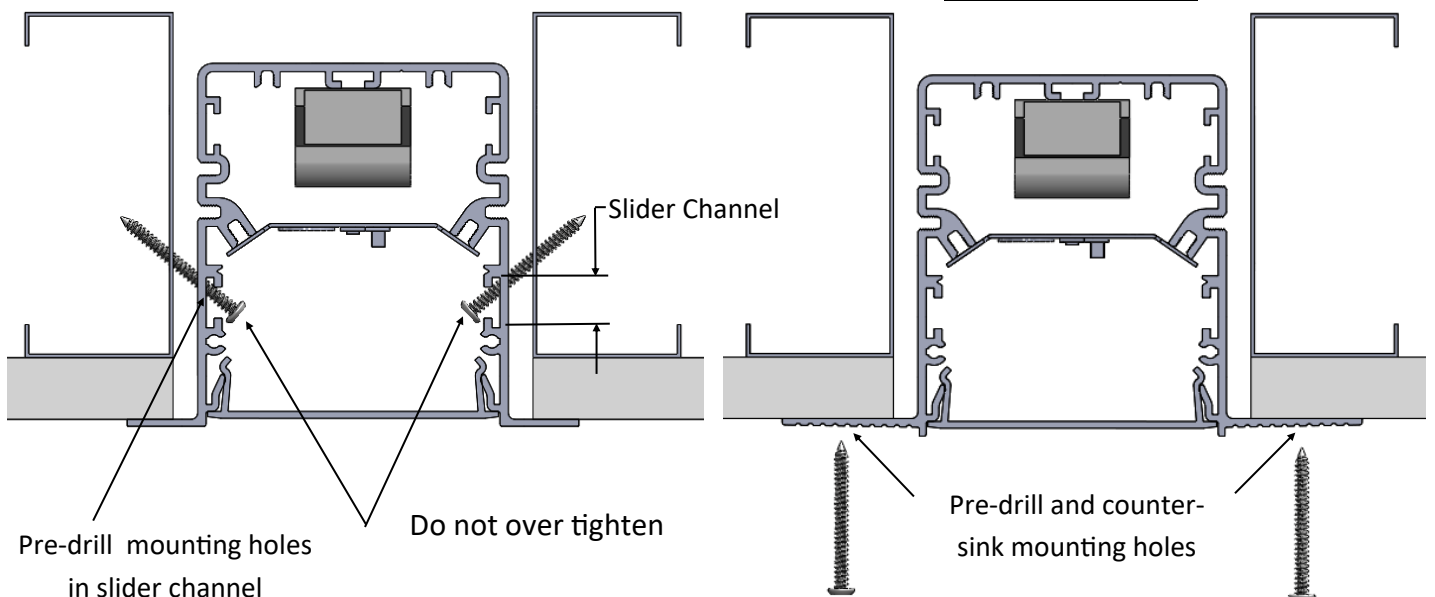

Pre-drill mounting holes in slider channel

Do not over tighten

Pre-drill and counter-sink mounting holes

Installation Instruction Sheet

Linear Fixtures

INSTALLATION INSTRUCTIONS FOR POWER FEED

For feed, attach the building power to the starter harness and plug into fixture thru harness. Attach dimming harness where dimming is required.

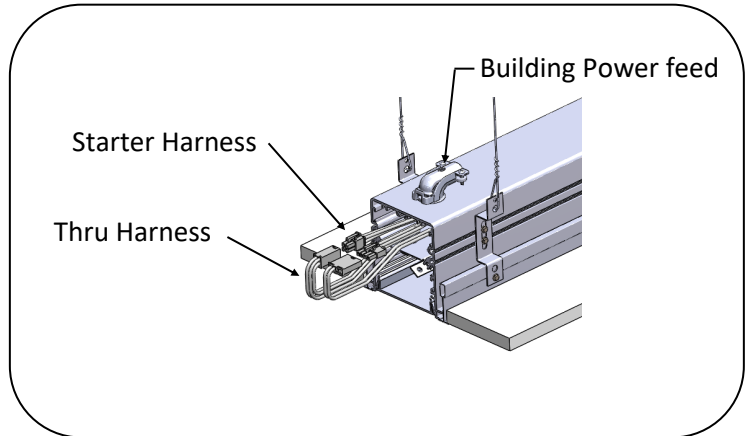

For special circuitry consult factory	
LINE WIRE COLOR	CIRCUIT DESCRIPTION
BLK	CIRCUIT A—HOT
WHT	CIRCUIT A & B— NEUTRAL
RED	CIRCUIT B— HOT
GRN	GROUNDING
VLT	DIMMING CONTROL 1
PINK OR GRY	DIMMING CONTROL 2
ORG	EHS or EHF—HOT
WHT/ORG	EHS or EHF— NEUTRAL

Compliant to UL 1598



General Wiring Diagram

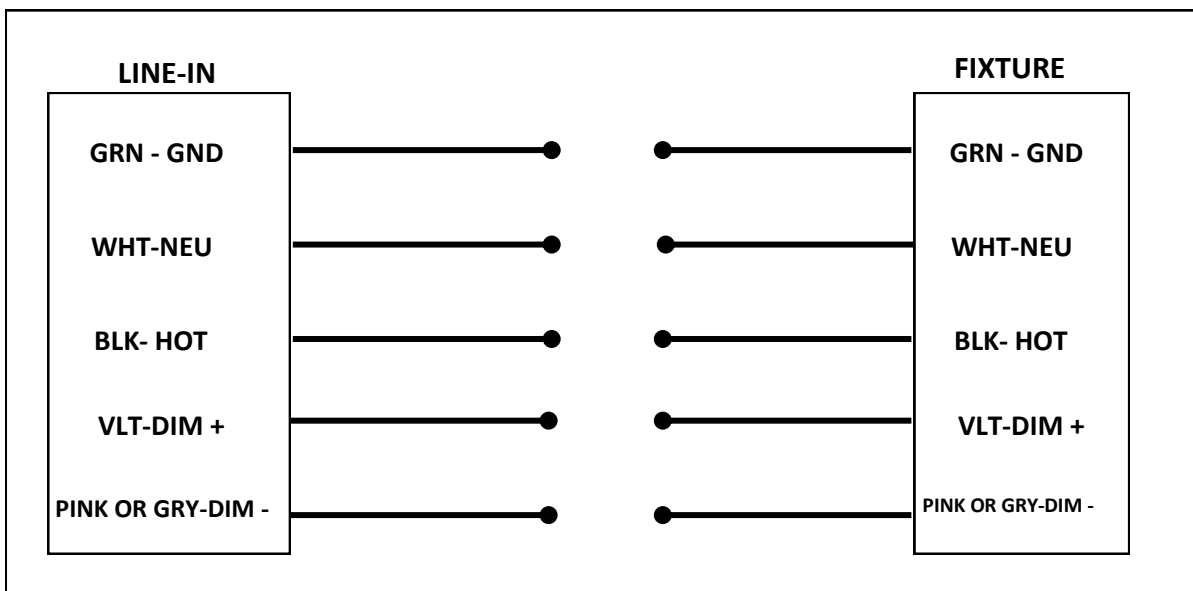

SUPPLEMENTAL INSTRUCTION FOR LENS REMOVAL AND ROW MOUNTING

LENS REMOVAL PROCEDURE:

Be sure to bow the lens during installation and servicing of the fixture to avoid damaging the gaskets on the endcaps. When removing the lens, use the provided suction cup in the middle of the lens so it will bow when removed.

To reinsert lens, bow from the middle and insert one end of the lens into the fixture and slide it all the way against one end gasket. Then, still holding the bow in the lens, insert the opposite lens end and allow the bow to relax to the lens end slides against the other end gasket. Continue snapping the lens into position.

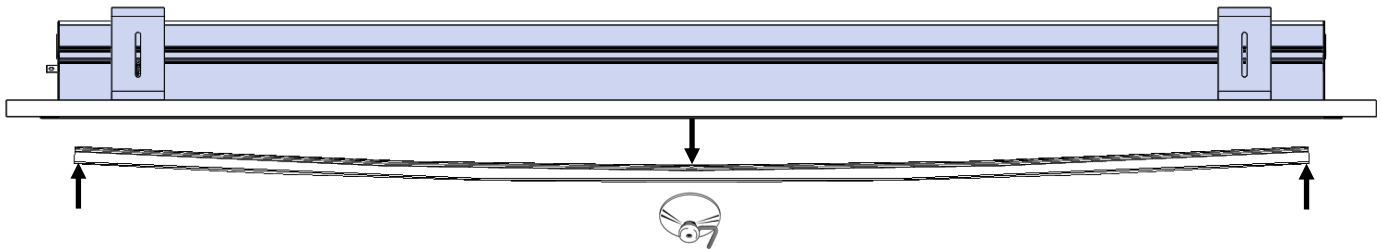

ROW MOUNTING PROCEDURE:

The lens and reflectors must be removed to access the wiring and attachment point for row mounting.

Place pipe nipple and one locknut (in hardware bag) on the end of one fixture to be joined.

Place gasket over pipe nipple and studs so it will seal between the two fixtures when joined.

Cut connectors off ends of wiring harnesses to allow them to pass through the pipe nipple. Match up the colored wires between both fixture harnesses and wire nut (not supplied) them together.

Bring the two fixtures together and secure with two keps nuts and one locknut (in hardware bag).

Ensure the joint between fixtures is gasketed and tight.

Replace reflectors and lenses.

UPON INSTALLATION, SEAL ANY SEAM OR GAPS BETWEEN THE TRIM FLANGE AND CEILING USING AN APPROPRIATE WATER-PROOF SEALANT. RUN A BEAD OF SEALANT ALONG EACH FIXTURE JOINT, SEALING ANY GAP BETWEEN THE JOINING PLATES.

